

Cable Gland Accessories

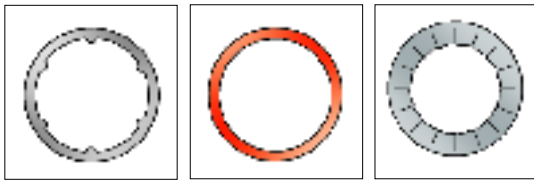

Nylon Sealing Washer

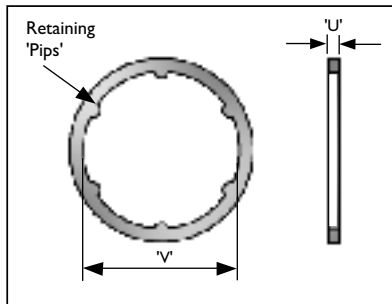

Red Fibre Washer

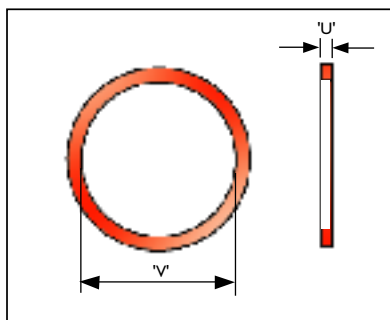

| SEALING WASHER SELECTION TABLE | | |
|--------------------------------|----------------------------|-----|
| Metric Cable Gland Size 'V' | NPT * Cable Gland Size 'V' | 'U' |
| M20 | 1/2" | 1.5 |
| M20 | 3/4" | 1.5 |
| M25 | 1" | 1.5 |
| M32 | 1 1/4" | 1.5 |
| M40 | 1 1/2" | 1.5 |
| M50 | 2" | 1.5 |
| M63 | 2 1/2" | 1.5 |
| M75 | 3" | 1.5 |
| M80 | 3 1/2" | 1.5 |
| M90 | 3 1/2" | 1.5 |
| M100 | 4" | 1.5 |

General Information

All dimensions in millimetres (except* where dimensions are in inches).
Hawke does not recommend the use of tapered entry threads in enclosures with plain clearance holes. Parallel threaded entries are recommended for this purpose.

Washers for M80, M90 and M100 sizes are only available in Red Fibre.

Application

- For use on cable gland entry threads.

Features

- To maintain ingress protection rating at the enclosure.
- Retaining 'Pips' make washer captive on metric cable gland entry thread.

Ordering Examples Sealing Washer Type/Size/ Thread

e.g. Nylon Washer/M25
Fibre Washer/M25

Serrated Washer

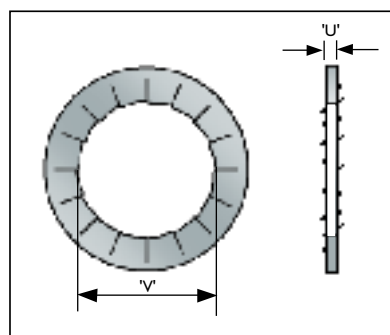

| SERRATED WASHER SELECTION TABLE | | |
|---------------------------------|----------------------------|-----|
| Metric Cable Gland Size 'V' | NPT * Cable Gland Size 'V' | 'U' |
| M20 | 1/2" | 1.5 |
| M20 | 3/4" | 1.5 |
| M25 | 1" | 1.5 |
| M32 | 1 1/4" | 1.5 |
| M40 | 1 1/2" | 1.5 |
| M50 | 2" | 1.5 |
| M63 | 2 1/2" | 1.5 |
| M75 | 3" | 1.5 |

General Information

All dimensions in millimetres (except* where dimensions are in inches).
Hawke does not recommend the use of tapered entry threads in enclosures with plain clearance holes. Parallel threaded entries are recommended for this purpose.

Application

- For use on cable gland entry threads.

Features

- To dampen vibrations of the cable gland/equipment assembly which may loosen the cable gland or locknut.

Materials & Finishes

Hawke serrated washers are manufactured as standard in stainless steel.

Ordering Examples Serrated Washer/Size/Thread

e.g. Serrated Washer/M25
Serrated Washer/1" NPT