

VIEW DN CABLE ENTRY SIDE OF BALLAST HOUSING

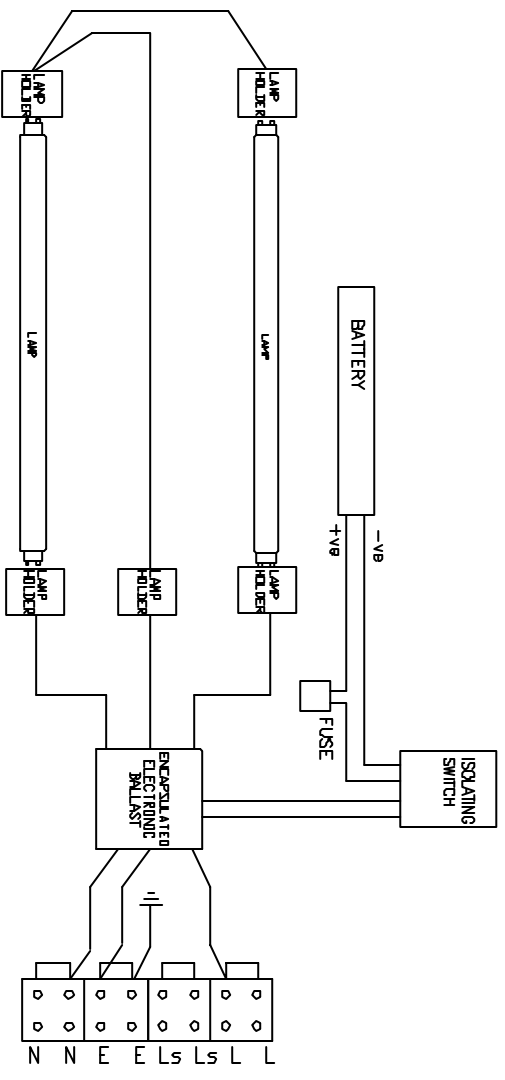
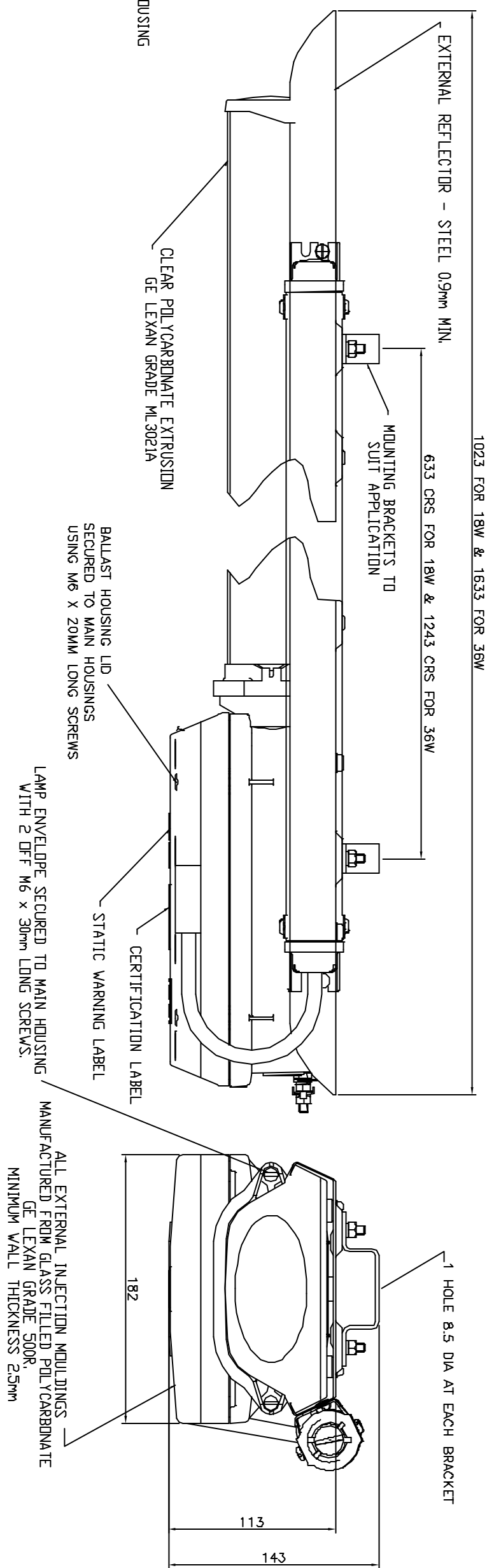

TYPICAL WIRING DIAGRAM

NOTES:
 PRODUCT PROTECTION: EEx emd II T4
 CERTIFICATE No: BAS00ATEX2191
 CODING: Ex II 2GD EEx emd IIC T4 -10C to +55C
 TERMINALS : UP TO 6MM SQ.
 CABLE ENTRIES : TWO X M20 ENTRIES
 INGRESS PROTECTION : IP66/67
 EXTERNAL BATTERY: 3HOUR DURATION
 EMERGENCY: 1 LAMP OPERATION

CATALOGUE REF.	DESCRIPTION	WATTAGE	LAMP	VOLTAGE	FREQUENCY
EXCE/218/BI/EM	EXCALIBUR VL24E	2 x 18W	BI PIN	220 - 277V	50-60Hz
EXCE/236/BI/EM		2 x 36W			
EXCE/218/BI/EM/120		2 x 18W			
EXCE/236/BI/EM/120		2 x 36W		110 - 130V	

DRAWN	JTC
CHECKED	JTC
APPROVED	JTC
DATE	21/02/06

WITHOUT OUR PERMISSION THIS DRAWING, WHICH IS OUR COPYRIGHT, MAY NOT BE REPRODUCED OR MADE AVAILABLE TO THIRD PARTIES.
 AUTHORIZATION IS GIVEN TO
 TO REPRODUCE THIS DRAWING FOR INTERNAL PURPOSES ONLY.

CHANGE	DCR NO	MOD BY	MATERIAL	FINISH	TOLERANCE	SCALE	DATE	TITLE
			GRP/POLYCARBONATE	SELF	SURFACE ROUGHNESS			Victor Lighting 388 Hillingdon Road, Glasgow G52 4BL Scotland Tel:0141 810 9844 Fax: 0141 810 9842
								VL24E EXCALIBUR EMERG.

DIMS. IN MM

SCALE - NTS

DRAWING NUMBER/SHEET NUMBER
F2281

Victor Lighting