

Cleats & Cable Fixings

Trefoil Cleats Aluminium Single and Two Bolt



Description



- > Suitable for cables in Trefoil groups - cable diameter 24 - 76mm
- > 33 sizes in range
- > Can be used with all types of cable routes
- > Supplied complete with top fastening
- > Available as either single or two fixing design
- > Plain finish for indoor dry normal industrial use or outdoor unpolluted areas
- > Epoxy coated for more hostile conditions
- > Operating temperature -60°C to +100°C
- > Single fixing
 - Plain finish -376AC Type
 - Epoxy coated -376AE Type
- > Two fixing
 - Plain finish -376AB Type
 - Epoxy coated -376AD Type

Application



- > These cleats are suitable for use at a maximum fault level of 30kA rms. Recommended maximum spacings, straight runs 900mm, vertical bends 300mm and horizontal bends on each support with, if necessary, intermediate unanchored cleats to limit resistance spacing to 300mm.
- > In all applications the cleats should be mounted on either one or two M10 fixings as appropriate. It is essential that they are secured to supports capable of withstanding the prospective short circuit forces.

Trefoil Cleats Aluminium Single and Two Bolt

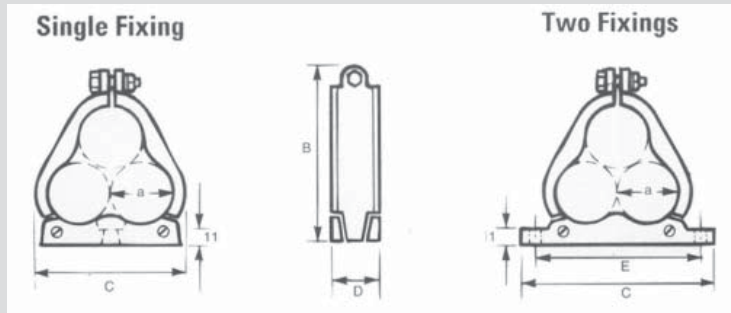

Cable and Cleat Details

Cable & Cleat Selection				Cleat Details						Approx. weight (g)	
Design Number		Cable Diameter A (mm)		Dimensions (mm)							
376AC** 376AE**	376AB** 376AD**	Min	Max	B	D	Single Fixing	Two Fixing		Single Fixing	Two Fixing	
						C	C	E			
01	01	24	25	94	38	75	128	102	234	276	
02	02	25	27	97	38	75	128	102	241	284	
03	03	27	28	100	38	75	128	102	248	291	
04	04	28	30	103	38	76	130	104	255	298	
05	05	30	32	105	38	79	133	107	269	305	
06	06	32	34	106	38	83	135	109	284	312	
07	07	34	35	109	38	86	137	110	291	319	
08	08	35	36	113	38	89	138	113	298	326	
09	09	36	38	116	38	92	140	114	305	333	
10	10	38	40	119	38	95	145	118	312	340	
11	11	40	41	122	38	99	147	121	319	347	
12	12	41	43	124	38	105	149	123	326	354	
13	13	43	44	127	38	108	150	124	340	369	
14	14	44	46	130	38	112	154	128	354	383	
15	15	46	48	133	38	114	156	129	361	390	
16	16	48	49	137	38	118	159	133	369	397	
17	17	49	51	140	38	121	165	135	376	404	
18	18	51	53	143	38	124	165	137	383	411	
19	19	53	54	146	38	127	172	141	390	418	
20	20	54	55.5	155	44	133	183	152	503	560	
21	21	55.5	57	158	44	137	187	155	517	574	
22	22	57	59	160	44	141	189	157	532	588	
23	23	59	60	163	44	145	191	160	546	602	
24	24	60	62	165	44	148	194	162	552	617	
25	25	62	63.5	168	44	152	196	165	567	631	
26	26	63.5	65	172	44	156	199	168	581	645	
27	27	65	66.5	176	44	160	202	170	602	666	
28	28	66.5	68	178	44	164	205	173	624	687	
29	29	68	70	181	44	168	208	176	652	716	
30	30	70	71.5	187	44	171	215	183	680	745	
31	31	71.5	73	190	44	175	217	186	695	758	
32	32	73	74.5	193	44	179	220	188	709	773	
33	33	74.5	76	197	44	183	222	191	722	787	