

## Cleats & Cable Fixings

## Packing Pieces, Adaptor Plates and Lindaptor Fittings

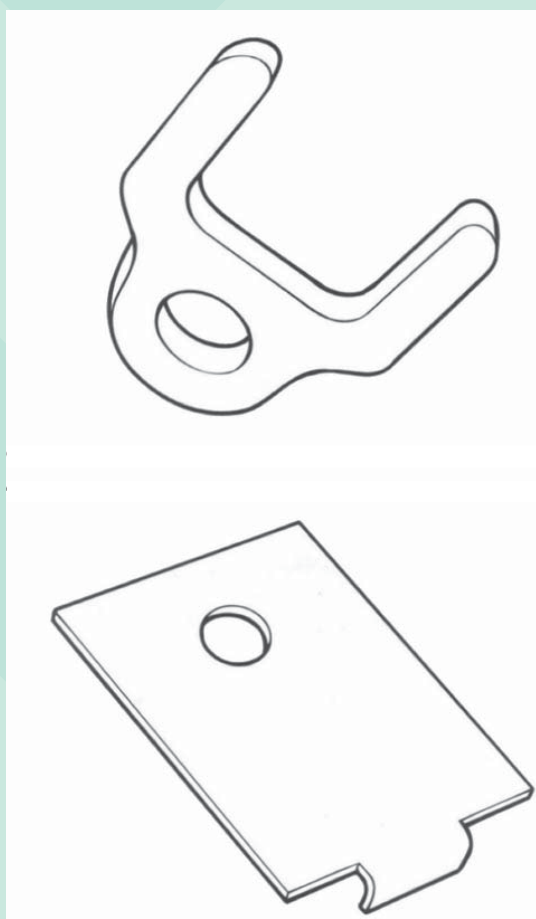

### Description



Reference Number	Packing Piece Description
389AC01	Cast iron, hot dip galvanised
389AC02	Cast iron, epoxy coated
389AC03	Aluminium alloy
389AC04	Aluminium alloy, epoxy coated

\*Required when stacking claw cleats

Reference Number	Adaptor Plate Description
380AG01	M6 (Galvanised)
380AG02	M10 (Galvanised)
380AG03	M12 (Galvanised)
380AG31	M6 (Epoxy Coated)
380AG32	M10 (Epoxy Coated)
380AG33	M12 (Epoxy Coated)

Reference Number	Lindaptor Fitting Description
389AA03	Cast iron (Hot dip galvanised)