

# Cleats & Cable Fixings

## Two Bolt Cleat

**BICON**

### Description

- > Suitable for use with cables from 50 to 94mm in diameter
- > Available in 7 sizes
- > Sunlight (UV) and weather resistant
- > Two-piece, two fixing design
- > Operating temperature -20°C to +90°C
- > Can be double stacked on common fixings
- > Black high-density Nylon 66 - unaffected by corrosive environment, oils and many chemicals



# Two Bolt Cleat

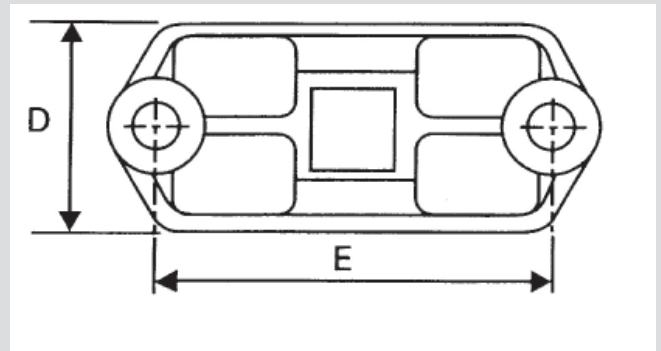
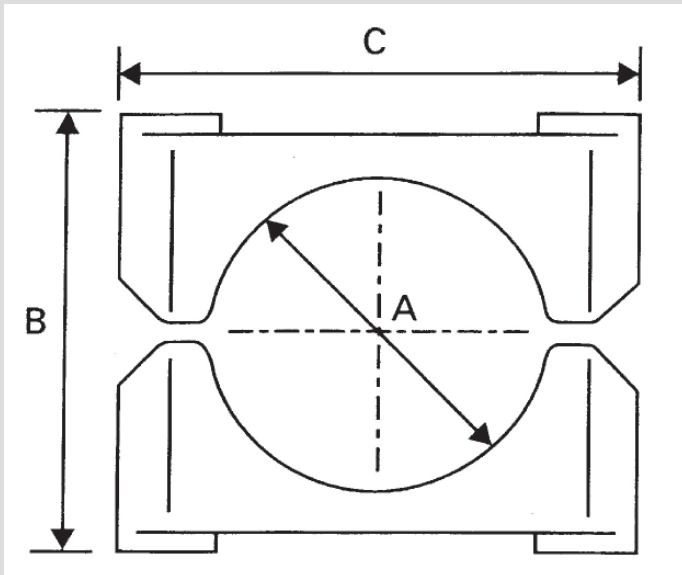

## Cable and Cleat Details

Cable & Cleat Selection			Cleat Details					SWL FOS2 (kgf) HD Nylon 66	Approx. weight per cleat (2 halves) (g) HD Nylon 66
Design Number	Cable Diameter A (mm)		Dimensions (mm)						
	Min	Max	B Max	C	D	E			
374AA01	50	58	89	102	45	80	560	97	
374AA02	56	64	93	102	45	80	590	98	
374AA03	62	70	98	114	45	92	530	106	
374AA04	68	76	104	114	50	92	705	132	
374AA05	74	82	110	126	50	104	710	154	
374AA06	80	88	118	126	50	104	765	160	
374AA07	86	94	121	136	60	114	750	204	

### METHOD OF FIXING

In all applications the cleat should be mounted on suitable M10 fixings.

There is no need for any channel adaptor when mounting directly on to 'C' section channel.

SWL = Safe Working Load

FOS 2 = Values include a Factor Of Safety of 2.