

Assembly Instructions for cable gland: CSB 656 Exd IIC/Exe II ExtD 656 EExd I/EEEx I

Operating temperature range -60°C +80°C

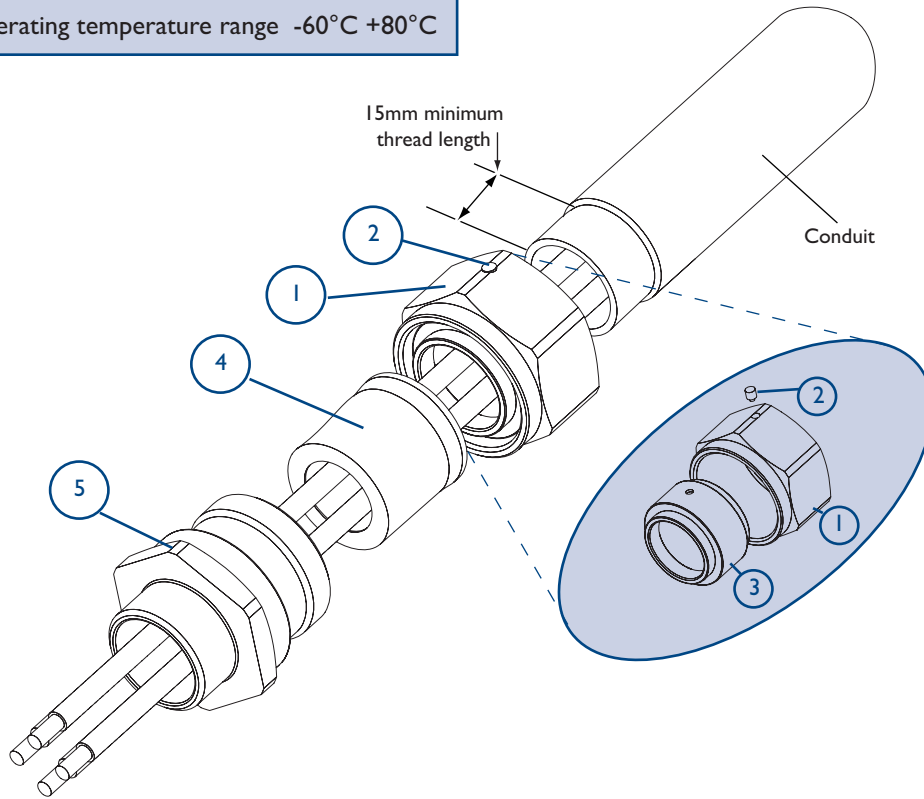

Certification Details

Gland Type: CSB 656 Exd IIC/Exe II/ExtD
Baseefa No: 06ATEX0058X Ⓢ II 2 GD A21 IP66 Ⓒ
IEC Ex No: BAS06.0015X
GOST R No: POCC GB.ГБ05.Б01 128
CSA No: 1024328 (LR 78713-9)

Gland Type: 656 EExd I/EEEx I
Baseefa No: 02ATEX0178X Ⓢ IM 2 IP66 Ⓒ
IECEX No: N/A

- | | |
|---------------------------|----------------|
| 1. Backnut | } Sub-Assembly |
| 2. Grub Screw | |
| 3. Spigot / Fixed Coupler | |
| 4. Rubber Pott | |
| 5. Entry | |

IMPORTANT: Prior to installation, it may be necessary to release conduit from its clamping mechanism to allow sufficient movement.

Cable Preparation

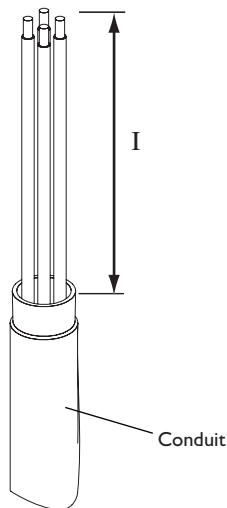

Gland Preparation

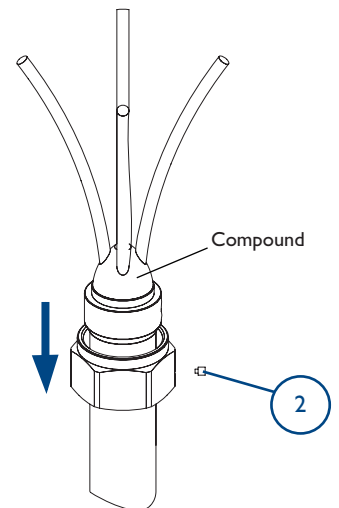
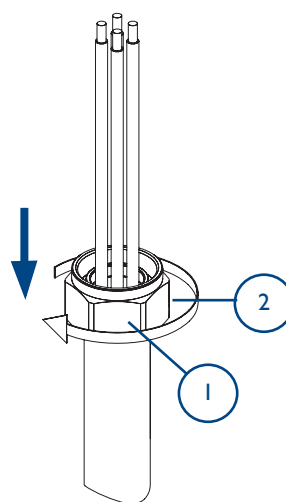

A Pull sufficient length 'I' of conductors through the conduit to suit equipment.

See Notes re. Drain Wires.

B Pass sub-assembly parts ①, ② and ③ over the conductors and start to thread onto the conduit, then using a spanner/wrench tighten the sub-assembly of parts ①, ② and ③ firmly onto the conduit.

C Remove the grub screw and push the backnut along the conduit to allow the compound to be installed. Spread the conductors out for the compound packing. Pack the compound between the conductors as shown.

See Notes overleaf and Fig. 7 for compound preparation.

Safety First

Hawke International is a division of Hubbell Ltd.
Registered No. 669157 in England. Registered Office:
Mitre House, 160 Aldersgate Street, London EC1A 4DD.
 A member of the Hubbell Group of Companies

Hawke International
UK Office
Oxford Street West,
Ashton-Under-Lyne,
Lancashire
OL7 0NA, UK

AI 311 - Issue L / Page 1 of 2
Sales (UK): 0870 606 0105
Sales: +44 (0) 161 830 6698
Technical (UK): 0870 458 9358
Technical: +44 (0) 161 830 6697
Fax: +44 (0) 161 830 6648
E-mail: sales@ehawke.com

www.ehawke.com

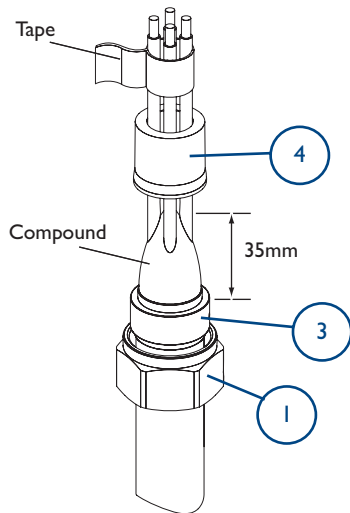

D With all gaps and voids filled, bring the conductors back together and pack more compound around the outside of the conductors. Tape the conductors together to prevent disturbance of the compound seal. Pass the rubber pot ④ over the spigot ③ and remove any surplus compound from the top of the rubber pot ④ and the joint face as indicated.

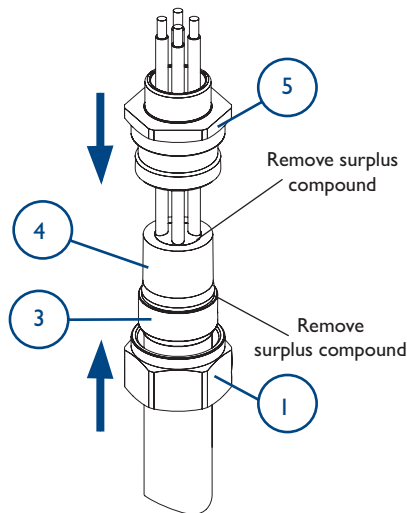

E Pass the conductors through the entry ⑤, which may have been previously fitted into the equipment. Ensure that compound does not cover end of the rubber pot ④. Fit the rubber pot ④ into the entry ⑤.

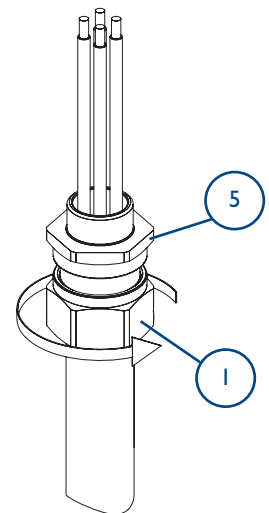

F Locate and hand tighten backnut ① to the entry ⑤.

IMPORTANT: The conductors must not be moved for a minimum of four hours.

EPOXY COMPOUND PREPARATION

When handling this material, the gloves supplied must be worn. The epoxy compound is supplied in the form of a two part package. These should be mixed into the ratio of 1:1 until both colours have blended into one, without any streaks. Rolling and folding is the most satisfactory method of obtaining an even blend. Once mixed, the compound must be used within 30 minutes. After this time it will begin to stiffen. The compound should be kept at an ambient temperature of no less than 20°C prior to using. At lower temperatures it becomes difficult to mix. Should any compound come into contact with the skin it should be cleaned off with skin cleaner and not allowed to dry on the skin. Only compound for immediate terminations should be mixed.

The mixing and installation of the compound at an ambient temperature below 4°C is not recommended due to extended curing periods.

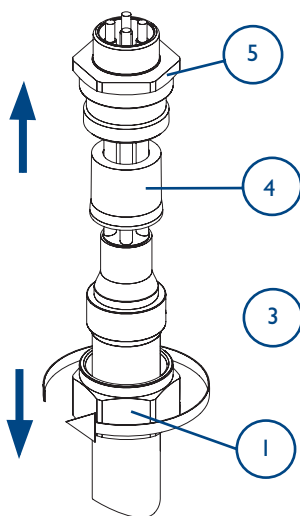

G Allow the compound to cure. (See Fig. 7 for curing times). Untighten the backnut ① from the entry ⑤ to enable inspection. The rubber pot ④ may be removed for inspection to ensure that the compound packing is satisfactory. Add further compound if necessary.

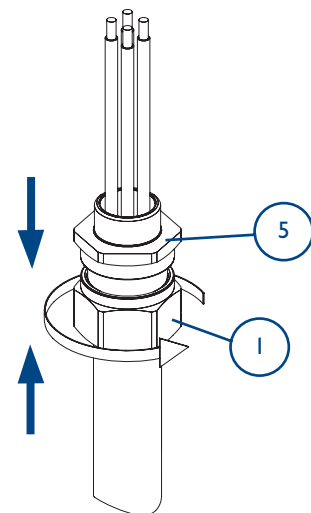

H Re-assemble the rubber pot ④ and the entry ⑤. Hand tighten the backnut ① onto the entry ⑤ and add half a turn with a spanner/wrench.

The following instructions are the various BASEEFA approved methods of passing drain wires etc. through the compound barrier and should be followed if permitted by cable installation specifications.

DRAIN WIRE PREPARATION

1.0 INSULATING DRAIN WIRES WITH HEAT SHRINK OR COLD SHRINK TUBING

- 1.1 Fold back the armour / braid and bend it to right angles from the inner sheath.
- 1.2 Remove foils and tape level with the outer sheath, exposing the drain wires and insulated conductors. Cut back a further 10mm of inner sheath.
- 1.3 Pass 100mm length of heat shrink or cold shrink tubing over the drain wire until it comes into contact with the foils, then shrink the tubing evenly down onto the drain wire so that no air pockets occur.
- 1.4 To insulate the joint between the foils and the tubing a suitable piece of 10mm long shrink tubing or neoprene stretch tubing or a 10mm wide lap of PVC tape may be used.
- 1.5 After completing 1.1 to 1.4 on each drain wire, lay the armour / braid parallel to the cable, if applicable, then carry out instruction B.

2.0 INSULATING DRAIN WIRES / SCREENS WITH SEPARATE INSULATED CRIMPED CONDUCTORS OR SOLDERED CONNECTION

- 2.1 Fold back the armour / braid and bend to right angles from the inner sheath.
- 2.2 Remove a further 15mm of inner sheath (See Fig. 1).
- 2.3 Unravel one or two groups of wires from the screen wires, then remove the remainder of the screen wires (See Fig. 2).
- 2.4 Twist the group of screen wires into a pigtail and cut to 15mm long.
- 2.5 Crimp an insulated conductor to the pigtail with a suitable insulated butt ferrule (or soldered connection), leaving enough length of the insulated conductor to enable the remote end to be connected to the earth terminal in the equipment. (See Fig. 3). Note: There shall be a minimum of 10mm of compound on both ends of the crimped / soldered joint.
- 2.6 To insulate the joint between the screen wires and the insulated conductor, place one lap of PVC insulating tape over the exposed metallic joint.
- 2.7 After completing 2.1 to 2.6 on each drain wire, lay the armour / braid parallel to the cable. Then carry out instruction B.

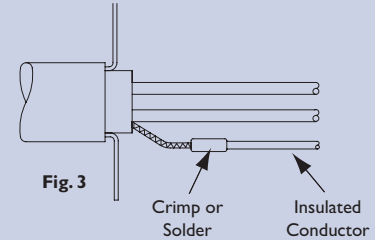
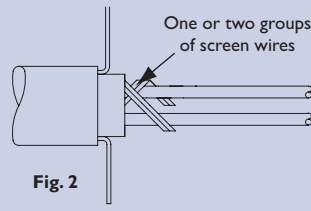
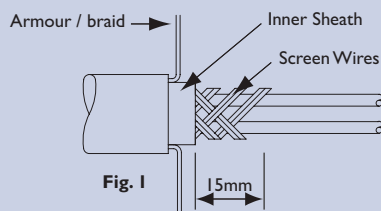

3.0 INSULATING DRAIN WIRES WITH INSULATING VARNISH OR PAINT

- 3.1 Fold back the armour / braid and bend it at right angles from the inner sheath.
- 3.2 Remove the foil and tape level with the inner sheath exposing the drain wires and conductor pairs.
- 3.3 Cut back a further 10mm of inner sheath (See Fig. 4).
- 3.4 Spray or paint the drain wires with insulating varnish or paint, then leave to dry (See Fig. 5).
- 3.5 To insulate the foil ends a suitable piece of 10mm long shrink tubing or neoprene stretch tubing or a 10mm wide lap of PVC tape may be used (See Fig. 6).
- 3.6 After completing 3.1 to 3.5 on each drain wire, lay the armour / braid parallel to the cable. Then carry out instruction B.

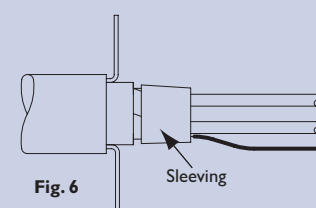
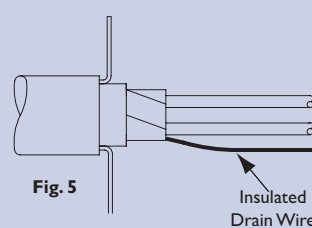
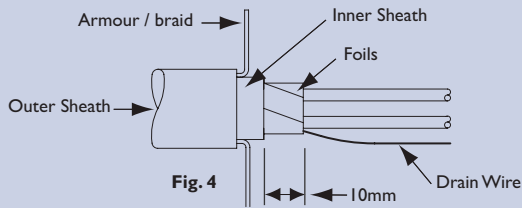

**Epoxy Compound
Cure Time Vs. Temperature**

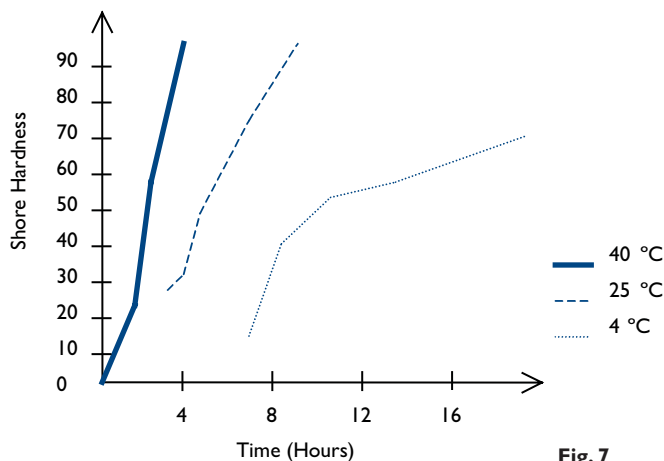

Fig. 7

- The compound may be adversely affected by some solvent vapours. If such vapours are likely to be present in the vicinity of the cable gland in service, suitable precautions may be necessary. (Contact Hawke's Technical Dept).
- The compound cures at a Shore D hardness of 85, when it can be handled. When used in the ICG653/UNIV cable gland, shown here, the compound when fully cured is suitable for use at a temperature range of -60°C to +80°C.

CABLE GLAND SELECTION TABLE

Size Ref.	Male Entry Thread Size		Female Entry Thread Size		Inner Sheath/Cores			Max Length	Hexagon Dimensions		Allen Key Size (mm)
	Metric	NPT	Metric	NPT	Max. Over Cores	Max. Inner Sheath	Max. No. of Cores		Across Flats	Across Corners	
A	M20	½" - ¾"	M20	½" - ¾"	11.0	12.5	10	56	30.0	34.6	2.0
B	M25	¾" - 1"	M25	¾" - 1"	16.2	18.4	21	56	36.0	41.6	2.0
C	M32	1" - 1¼"	M32	1" - 1¼"	21.9	24.7	42	58	46.0	53.1	2.0
C2	M40	1¼" - 1½"	M40	1¼" - 1½"	26.3	29.7	60	58	55.0	63.5	2.5
D	M50	1½" - 2"	M50	1½" - 2"	37.1	41.7	80	64	65.0	75.1	2.5
E	M63	2" - 2½"	M63	2" - 2½"	47.8	53.5	100	64	80.0	92.4	2.5
F	M75	2½" - 3"	M75	2½" - 3"	59.0	65.3/66.2	120	68	95.0	109.6	2.5
G	M80	---	M80	---	62.8	74.0	140	70	106.4	123.0	2.5
H	M90	3½"	M90	---	70.9	83.0	160	70	115.0	132.8	2.5
J	M100	4"	M100	---	80.3	93.0	180	70	127.0	146.7	2.5

SCHEDULE OF LIMITATIONS:

1. This cable gland has an operating temperature range of -60°C to +80°C.
2. A seal must be formed between the equipment and the cable gland to maintain the appropriate degree of protection against ingress of dust, solid objects and water.

ACCESSORIES:

Before cable gland assembly or stripping of the cable gland assembly, consideration should be given to any cable gland accessories that may be required, such as: -

- Shroud, to offer additional corrosion protection.
- Locknut, to secure cable glands into position.
- Sealing washer, to offer additional ingress protection of the enclosure at the cable gland entry.
- Earthtag, to provide an external armour/braid bonding point.
- Serrated washer, to dampen any vibrations that may loosen the locknut or cable gland assembly.